

PFISTER® TRW-S/D ROTOR WEIGHFEEDERS

**For alternative fuels -
Multi-fuel system with high feeding accuracy**

HIGHLY ACCURATE AND RELIABLE GRAVIMETRIC FEEDING

for a variety of alternative fuels and biomass

KEY BENEFITS

**Only ONE feeder for multiple
AF dosing materials**

**High short and long-term
dosing accuracy**

**Online calibration possible
during operation**

Completely dust-tight

**ProsCon® prospective control
with flow balance control**

**Available with
PFISTER® Remote Support**

MULTI-FUEL SYSTEM WITH HIGH FEEDING ACCURACY

Standard or explosion proof execution according to your needs

Multi-fuel system

Rotor weighfeeder Pfister® TRW-S is a multi-fuel system. One of the major issues when dealing with solid alternative fuels is to find a reliable supplier. It is most likely that the source and therefore the material characteristics change. FLSmidth Pfister has experience in nearly all kinds of materials. Because of the large amount of weighed material in the system, it is possible to feed fuels with a very low density. The system is designed to handle fuel material densities from 0.05 t/m³ to 1.5 t/m³ with the same machine, so that there is maximum flexibility for the customer.

High feeding accuracy

Rotor weighfeeder Pfister® TRW-S is dosing with high accuracy resulting in a guaranteed maximum deviation of the actual and set feed rate of ±1.0 %. Along with the high reliability it supplies fuel feeding for a very constant kiln operation. Very light materials such as plastic could be difficult to measure because of their very low gravimetric force. This is solved with Pfister® rotor weighfeeders measuring a material layer of up to 500 mm in the feeder without the risk of material spilling. The relatively large mass of bulk material in the Pfister® rotor weighfeeder leads to a high momentary load in the measuring section of the feeder.

Explosion-proof

When feeding burnable material there is always the danger of unintentional fires or even explosion of dusty materials. In some

Main Features

- Dosing of varying fuels possible with one and the same rotor weighfeeder Pfister® TRW-S/D
- Feed up to 27 t/h with densities down to 0.05 t/m³
- Calibration pre-hopper with stirrer for online calibration during operation
- Rotary valve for transfer into the pneumatic feeding line
- Compact, robust, closed dosing system
- Explosion-proof design optional

countries it is necessary to have an explosion proof equipment when handling such dangerous materials. The Pfister® secondary fuels dosing system can be designed explosion-proof for up to 10 bars pressure overload. Rotor weighfeeder Pfister® TRW-D is approved according to EC-type examination.

Completely dust-tight

This prevents environmental pollution and the emission of dust or odor. However, the necessary maintenance work should be minimal and easy to fulfil. Rotor weighfeeder Pfister® TRW-S/D realises both. The rotor weighfeeder is a completely closed unit and dust-free

Minimal maintenance

Maintenance work at the rotor weighfeeder is kept on a minimal level since all machine parts in contact with material are fully steel. There is only one rotating part, the rotor wheel itself. There is no segregation of dust or spilled dirt at belt rollers or idler bearings. To rule out dust penetration the centre bearing is additionally purge air sealed. Thus, even with very dusty materials, there is less cleaning of the inside necessary.

Fuel homogenisation in the silo

The pre-feeder with stirrer arm above the rotor weighfeeder provides several advantages. It homogenises the material by a stirrer to give an steady fuel quality. Additionally it ensures a steady loading of the rotor weighfeeder even if there is a short interruption of material supply or if the pre-feeder is fed over a longer distance. Together with load cells it can be used for periodically online calibration of the rotor weighfeeder. That means that the static weighing result of the material content difference in the homogenisation silo can be compared with the continuous weighing result of the rotor weighfeeder.

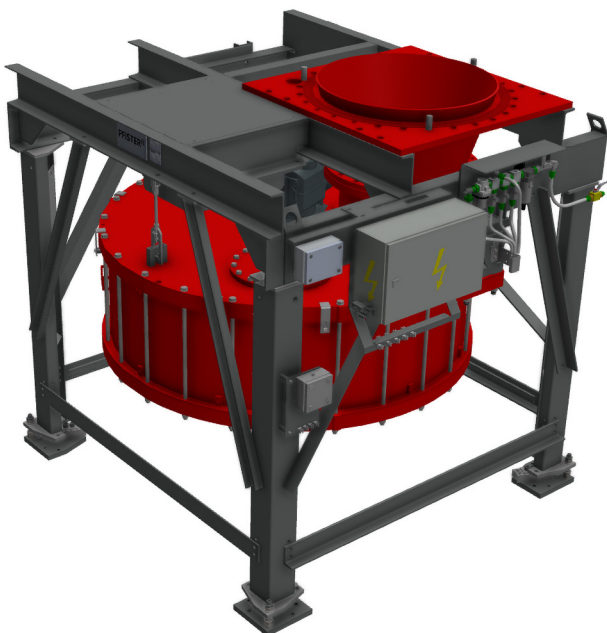

MULTIFUEL DOSING WITH ROTOR WEIGHFEEDER PFISTER® TRW-S/D

Alternative fuels are also known as:

- Refuse derived fuels (RDF)
- Clima fuels
- Secondary fuels
- Biomass [e.g. wood chips, saw
- Dust, sewage sludge, animal meal]
- Industrial waste

The pictures on the right display a selection of alternative fuels which are handled by a rotor weighfeeder Pfister® TRW-S/D.

This multifuel device is able to handle different alternative fuels no matter whether these are dry or moist, chipped or chunky.

Even if the composition and consistency of the fed alternative fuels are varying, rotor weighfeeder Pfister® TRW-S/D can handle them - all with one and the same system.



animal meal



carpet waste



textiles



car-plastic

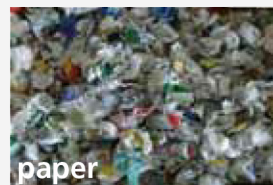

paper



bottle caps



rice straw and husk



granulated plastic

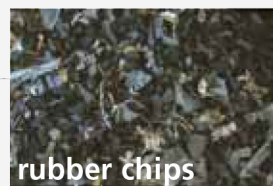

rubber chips



grinding dust



sewage sludge



saw dust



sunflower shells

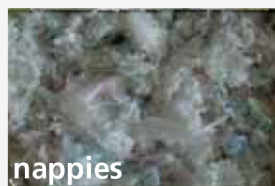

nappies

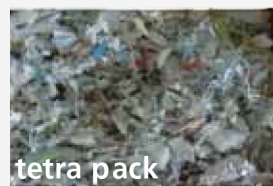

tetra pack

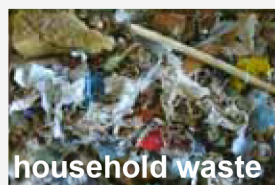

household waste

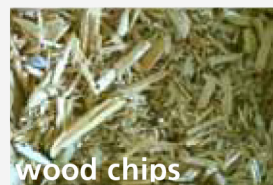

wood chips

REAL RESULTS

Improve cement quality while reducing environmental footprint



AF feeding with Pfister® TRW-D to the main burner

In this installation the Pfister® TRW-D rotor weighfeeder is used for feeding fluffy and dusty alternative fuels with a feed rate of 8 t/h. For this purpose the Pfister® TRW-D rotor weighfeeder is executed in ATEX and shock pressure- proof design.

Stable and accurate dosing improves kiln performance



Pfister® TRW-S in the pre-heater tower to the pre-calciner

It is most suitable to place the dosing system as close to the firing spot as possible. This reduces dead time in dosing control. However, with an installation for the pre-calciner area the feeding systems need to be placed in the tower. The material gets transported e.g. by a tube-conveyor to the pre-hopper and when leaving the feeder outlet by screw conveyors to the pre-calcining area.

FLSMIDTH CEMENT

www.flsmidth-cement.com

Copyright © 2025 FLSmidth Cement. All Rights Reserved. FLSmidth is a (registered) trademark of FLSmidth A/S, and FLSmidth Cement is authorized to use the trademark under a license agreement. This brochure makes no offers, representations or warranties (express or implied), and information and data contained in this brochure are for general reference only and may change at any time



C 01-25-700-23 ENG