

SPLIT AIR SEAL

Our split air seals simplify seal inspection, adjustment, and replacement, extending seal integrity and operating life and supporting optimal equipment performance.

KEY BENEFITS

- Simplify seal maintenance
- Cut replacement costs
- Protect oil seals
- Extend equipment life

SEALS THAT IMPROVE OPERATIONAL RELIABILITY

The air seal between a mill roller and joint head sits over and protects an inner oil seal. This prevents oil contamination, which can cause wear of the shaft and bearings and impact mill performance.

These seals traditionally come as single pieces and require removing the head joint to install and replace—a complex and time-consuming undertaking. This means seal maintenance is often delayed until a major shutdown, risking seal failure and subsequent equipment damage.

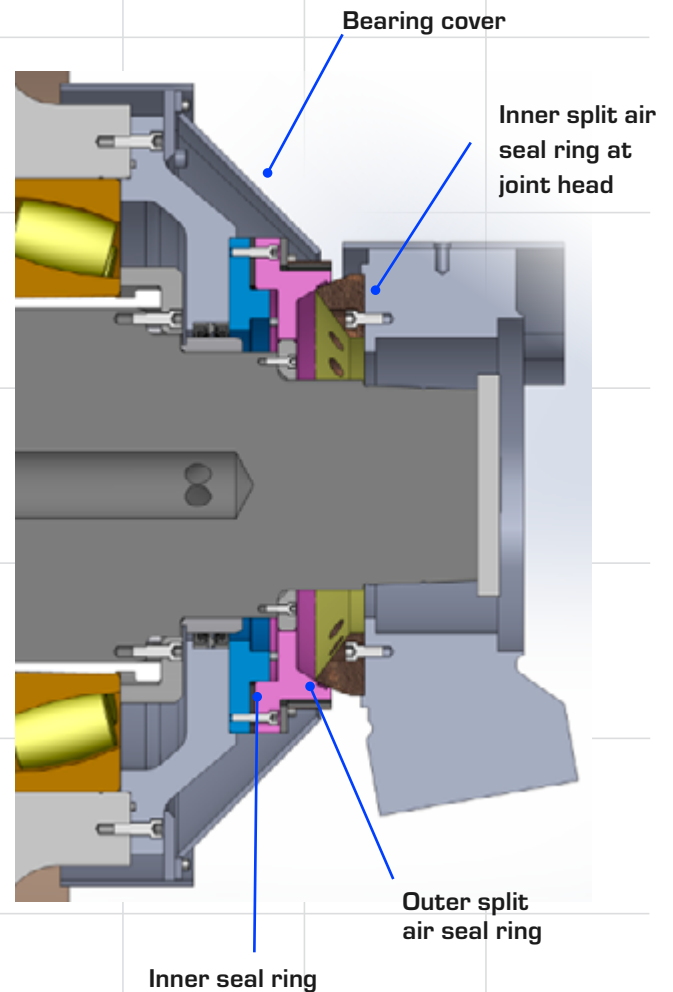

The new split design eliminates the need to disassemble the head joint to remove the seal, allowing more frequent replacement. The seal air gap can also easily be adjusted by adding shims. The result is improved sealing performance and increased operational reliability.