

Wave Grate for the SF™ Cross-Bar® and Multi-Moveable Cross-Bar® cooler

Reduce power consumption
and maintenance costs



Designed to reduce costs and save time

Operate and maintain your SF™ Cross-Bar® or Multi-Moveable Cross-Bar® cooler more efficiently by switching to the Wave Grate. Compared with the original grates, the Wave Grate is easy to clean and maintain, has an increased wear lifetime, and reduces power consumption. Once installed, you only ever need to replace the upper grate, which is fast and straightforward.

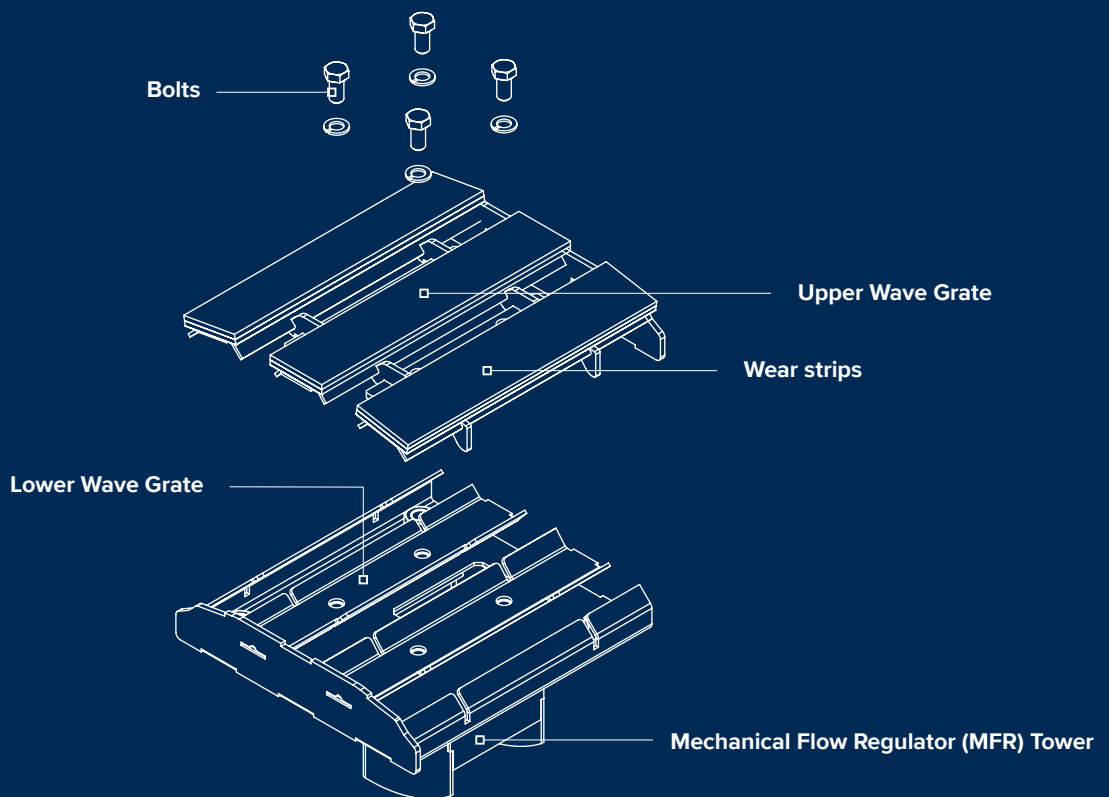

Key benefits

■
Reduce power consumption

■
Easy to clean and maintain

■
Increase grate wear lifetime

■
Fast and simple installation

Reduce power consumption

The Wave Grate helps you to operate the SF™ Cross-Bar® or Multi-Moveable Cross-Bar® cooler more efficiently. By replacing the older type grates with the Wave Grate, you can reduce the power consumption of the cooler fans. The design of the Wave Grate reduces airflow resistance through the grate, which results in a significant reduction in pressure drop.

Industrial test results show approximately an 8% reduction in total pressure drop, providing up to 0.5 kWh/t reduced power consumption of cooler fans when modifying all the cooler grates.

Increase heat recuperation efficiency

Many plants are stretching the cooler above its designed capacity. As an alternative option to saving power, plants could use the reduced pressure drop to increase the cooling airflow in a heavily loaded cooler, with the potential to increase the heat recuperation efficiency and reduce clinker exit temperature.

Save maintenance costs and time

The two-piece grate design means that the upper part of the grate can be removed, making it easy to clean inside the grate if needed. The upper Wave Grate with wear strips is the only wear part that needs replacement and has an expected lifetime of more than five years.

To change the upper Wave Grate, you access the bolts from above the cooler grate line. This is an advantage compared to the older grate design, where you have to access both the top and bottom of the grate line. This significantly reduces your costs as well as maintenance time.

	Original grate	Wave Grate
Pressure drop	770 - 1000 Pa*	330 - 430 Pa*
Expected wear lifetime	3-5 years	> 5 years
Design	Single piece grate	Two-piece design for easy maintenance
Wear replacement part	Entire grate/ side wear strip	Only upper part
Maintenance	Time consuming	Easy and simple

*based on test results on a SF Cross-Bar cooler with air flux 70-80 (kg/m²/min)

Fast return on investment

Wave Grates, in comparison to the original grate design, typically result in a return on investment in less than one year.

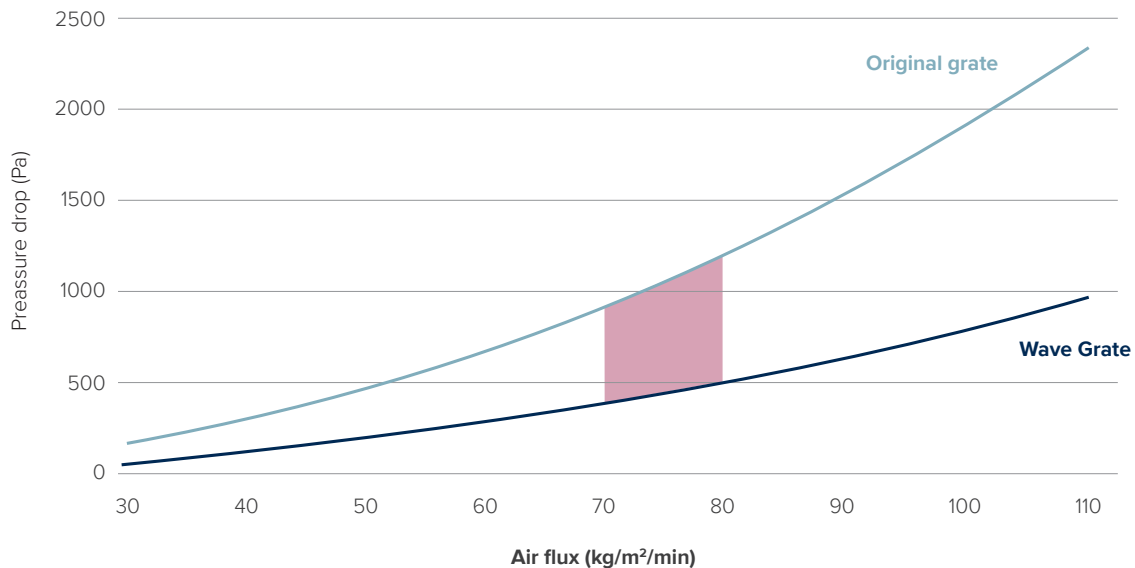

Based on industrial tests on a SF Cross-Bar cooler, the typical operating air flux range of 70–80 kg/m²/min, the pressure drop across the grates is reduced by ~60%, and the total pressure drop of the fan is reduced by ~8%.

FLSmidth A/S

Vigerslev Allé 77
2500 Valby
Denmark

Tel. +45 3618 1000
Fax +45 3630 1820
info@flsmidth.com

www.flsmidth.com



[flsmidth.com/linkedin](https://www.flsmidth.com/linkedin)



[flsmidth.com/twitter](https://www.flsmidth.com/twitter)



[flsmidth.com/facebook](https://www.flsmidth.com/facebook)



[flsmidth.com/instagram](https://www.flsmidth.com/instagram)



[flsmidth.com/youtube](https://www.flsmidth.com/youtube)