



# DRYER CRUSHER

Two processes in one impact crusher

# EFFICIENT AND RELIABLE CRUSHING OF SOFT, STICKY MATERIALS

Dry and crush raw materials in one dependable process to deliver a high-quality feed for downstream processes.

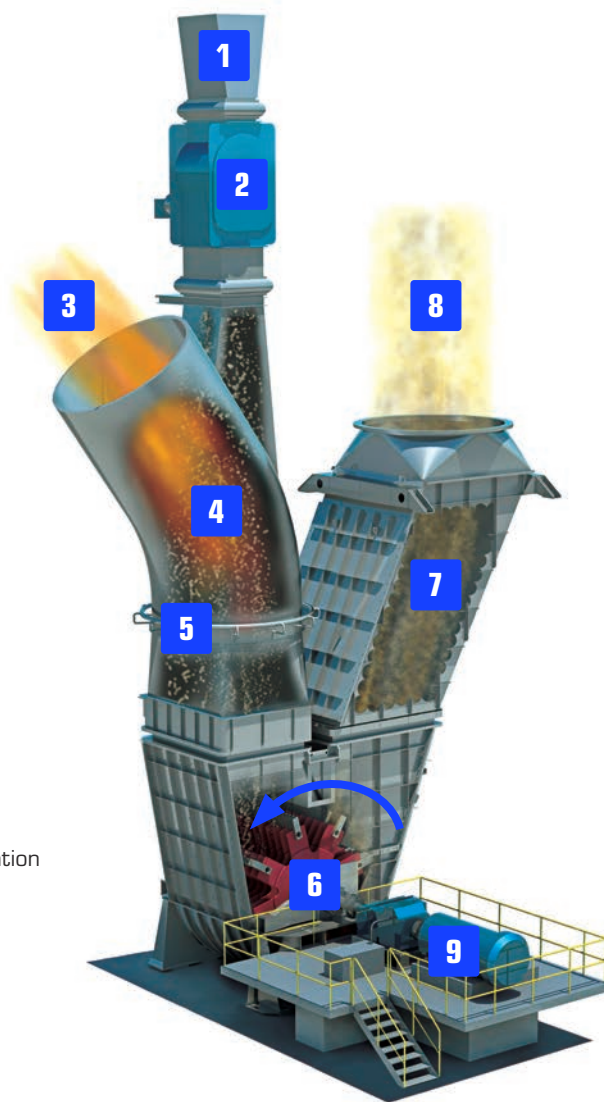
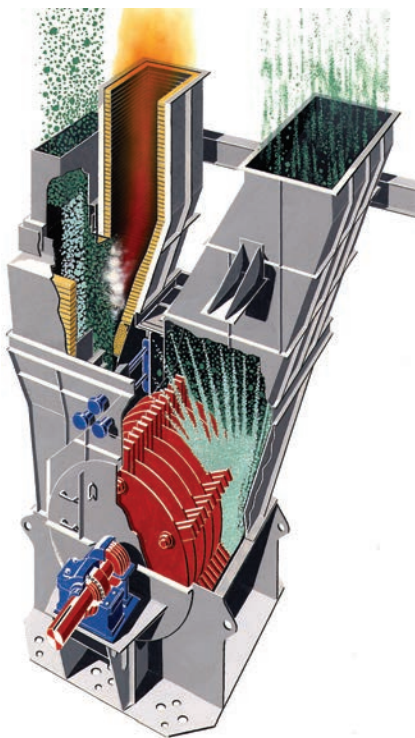

- 1. Material inlet
- 2. Rotary air sluice
- 3. Hot air inlet
- 4. Mixing chamber
- 5. Water injection nozzle
- 6. Rotor with hammers
- 7. Riser duct
- 8. Material outlet
- 9. Drive station

## KEY BENEFITS

- Dry and crush / disagglomerate in single operation
- Handle sticky materials up to 40% moisture
- Highly energy efficiency process
- Reliable with low maintenance costs



# ONE MACHINE FOR TWO JOBS

Doing more with less – without sacrificing quality, reliability, or efficiency – is a central tenet of sustainability. It's one we place particular emphasis on here at FLSmidth Cement. Our dryer crusher is a case in point. Designed for soft and sticky raw materials with moisture contents up to 40%, these versatile machines combine drying and crushing into one efficient operation. Applications suitable for low-abrasive materials, such as chalk, clay, marl, and slurry filter cake; they can also be used to dry slurry.

## Energy-efficient operation

For example, raw materials are fed into the dryer crusher through a self-cleaning rotary air sluice / box feeder. Slurry is injected through nozzles just above the rotor.

Our dryer crushers are designed to utilize hot gases from your pyroprocess equipment, such as cement preheaters or clay calciners, for maximum energy efficiency. These provide a continuous flow of hot air with an inlet temperature of 400°C to 800°C. This air sweeps through the dryer crusher, pre-drying the feed material as it enters the mixing chamber.

Drying continues as feed material passes through the impact hammers to deliver a product moisture content of about 1% with an outlet temperature between 130° to 150°C. The impact hammers efficiently crush feed material of up to 100-150 mm through impact with the hammers, collision between feed particles, and impact with the lined housing.

Past the crushing chamber, the system is designed to reduce unnecessary recirculation of material for optimum efficiency and productivity. Coarser material first drops out of the air stream in the riser duct and returns straight to the crushing zone. A high-efficiency dynamic separator then accurately removes any remaining oversized material, which is returned to the dryer crusher inlet. Finished product proceeds to the cyclones and filter.

When handling slurry or slurry filter cake, no separator is normally needed and the dried materials are carried directly to the cyclone/filter. The rated production depends on the drying requirements and the grindability of the materials.



### Reliable and low maintenance

Your dryer crusher will often be the first step in the production process. You depend on it to deliver a consistent and high-quality feed to your downstream process, day in, day out. Unnecessary or extended shutdowns dent productivity and hit the bottom line. It's why we've designed our dryer crusher to keep running reliably, with limited maintenance needs.

When it comes to the impact hammers, the dryer crusher is designed to allow easy access for safe and efficient maintenance. Worn hammers can be replaced without removing or dismantling the rotor. But in the unlikely event major workshop repairs are necessary, the layout also includes cranes to facilitate dismantling. The gear unit includes lubrication system and a barring drive, with all parts mounted on the same base frame to expedite installation and maintenance.

### Expert material analysis

We support you to select the most appropriate crushing solution with expert raw materials testing at FLSmidth Cement Dania, Denmark, and our laboratory in Chennai, India. These laboratories are some of the world's most advanced for raw material analysis and allow us to measure various parameters, such as hardness, abrasiveness, and stickiness. Understanding these factors allows us to optimise the process to your specific application requirements, as well as calculating the service life of the hammers.

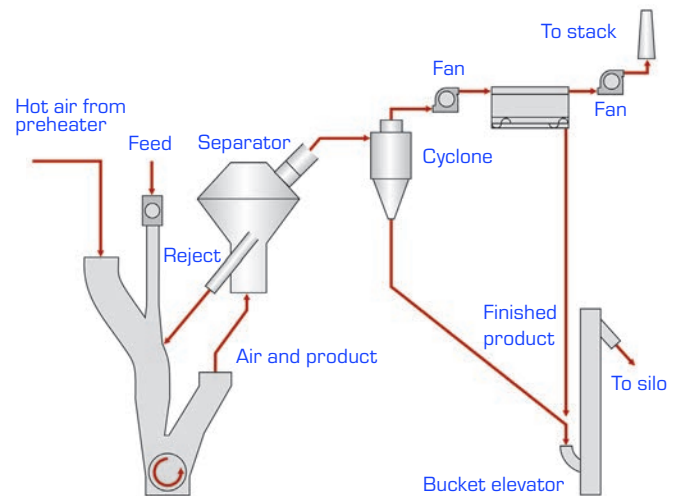

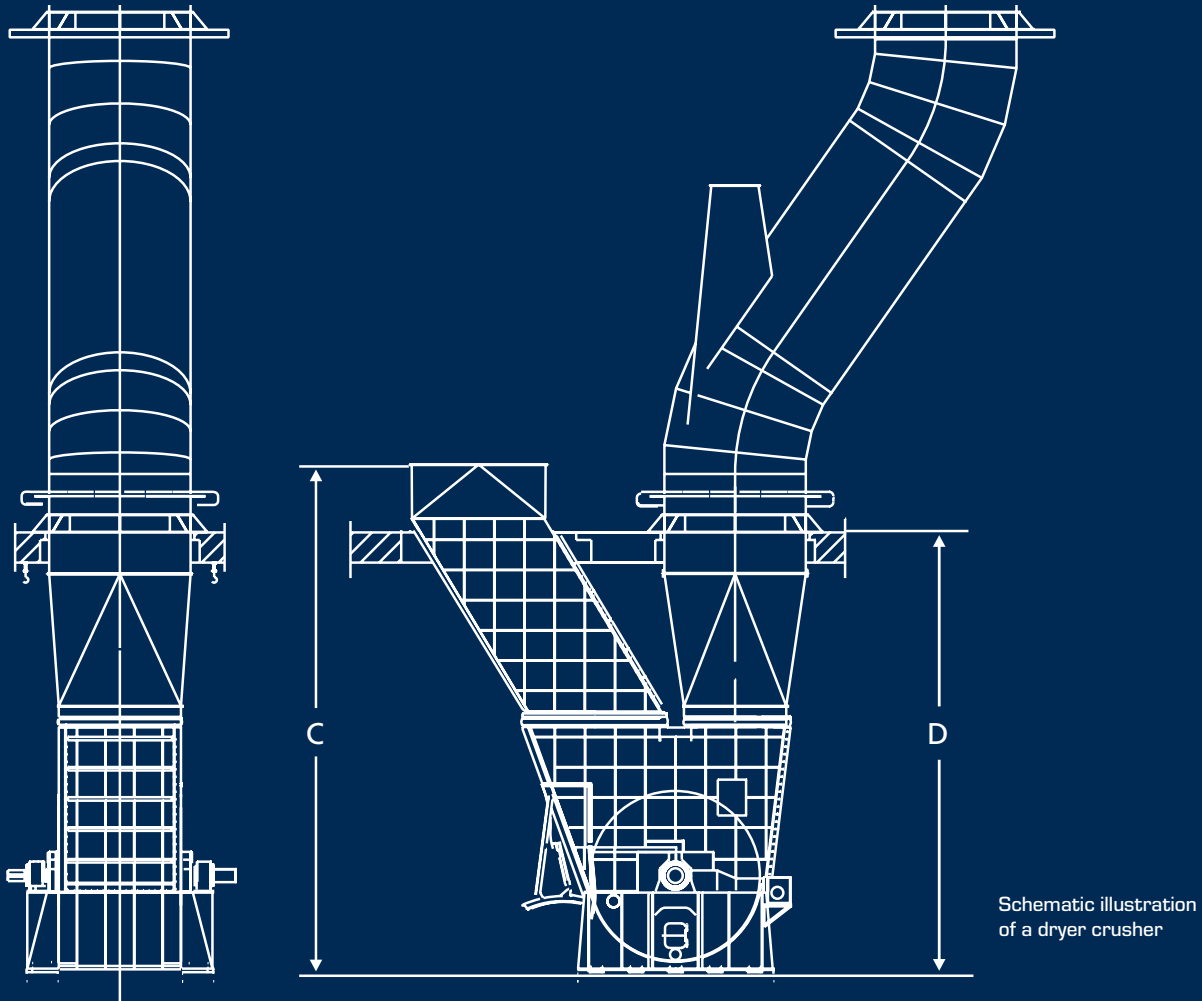

DIMENSIONS (MM)			INSTALLED POWER (UP TO)	PRODUCTION
SIZE	C	D	(KW)	(T/H)
150x100	9200	7100	600	26
150x138	9200	7100	600	35
250x100	9200	8100	1080	43
250x138	9200	8100	1080	59
250x175	7150	6300	1080	
250x225	7300	7350	1080	
355x200	10125	8750	1570	
355x250	10375	10500	1570	
355x300	10525	11550	1570	
450x275	13000	12250	2200	
450x330	13100	12950	2200	
450x400	13200	13650	2200	
450x450	13300	14350	2200	

**Dimensioning Table**

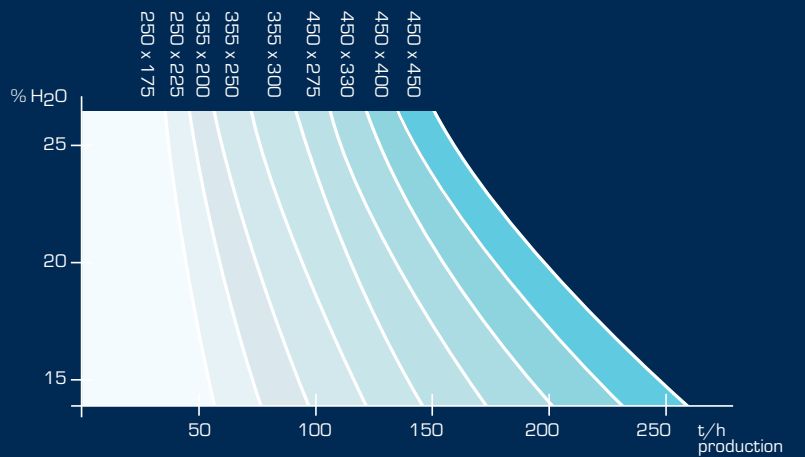

- The drying capacity increases with higher hot gas temperature.
- The design can be made for temperatures up to 800°C

The size designation of the dryer crusher, for example 355x200, indicates the diameter and the width of the rotor (in cm).



# FLSMIDTH CEMENT

[www.flsmidth-cement.com](http://www.flsmidth-cement.com)

Copyright © 2024 FLSmidth Cement. All Rights Reserved. FLSmidth is a (registered) trademark of FLSmidth A/S, and FLSmidth Cement is authorized to use the trademark under a license agreement. This brochure makes no offers, representations or warranties (express or implied), and information and data contained in this brochure are for general reference only and may change at any time.

