

One Source

Product Brochure Pfister® TRW-S/D



**Highly accurate and reliable feeding
for alternative fuels and biomass**



Watch here how Pfister® dosing solutions work!

FLSMIDTH
PFISTER

Rotor weighfeeder Pfister® TRW-S/D

Highly accurate and reliable gravimetric feeding for a variety of alternative fuels and biomass

There is a steadily growing requirement for the substitution of primary fuels by alternative fuels within all energy intensive industries. Compared to primary fuels solid alternative fuels are more difficult to handle because the material characteristics are widely changing in particle size, moisture and density.

Rotor weighfeeder Pfister® TRW-S/D fulfils the high requirements for stable multi-fuel dosing with highest

short- and long-term accuracy, outstanding reliability and a large feeding range up to 25 t/h capable to handle densities from 0.05 -1.5 t/m³. Rotor weighfeeder Pfister® TRW-S/D is available as an explosion-proof system up to 10 bar.

More than 250 rotor weighfeeders Pfister® TRW-S/D are successfully in operation throughout the world.

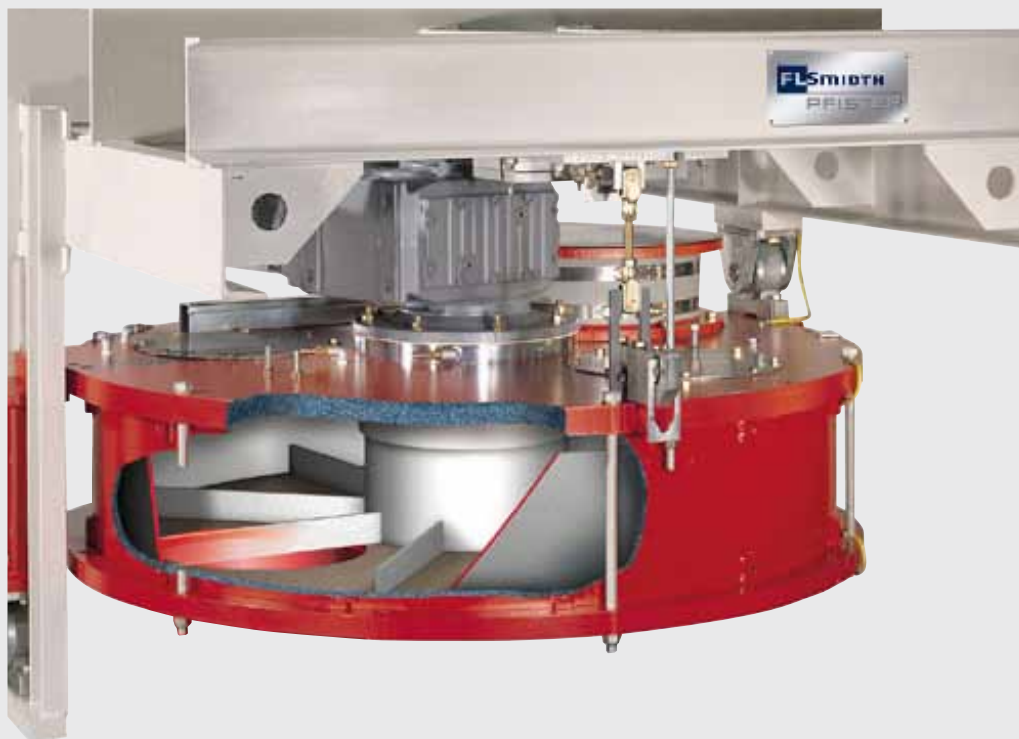

Dosing and feeding for industrial production

Pfister® feeding and dosing devices exemplary in the cement production process:

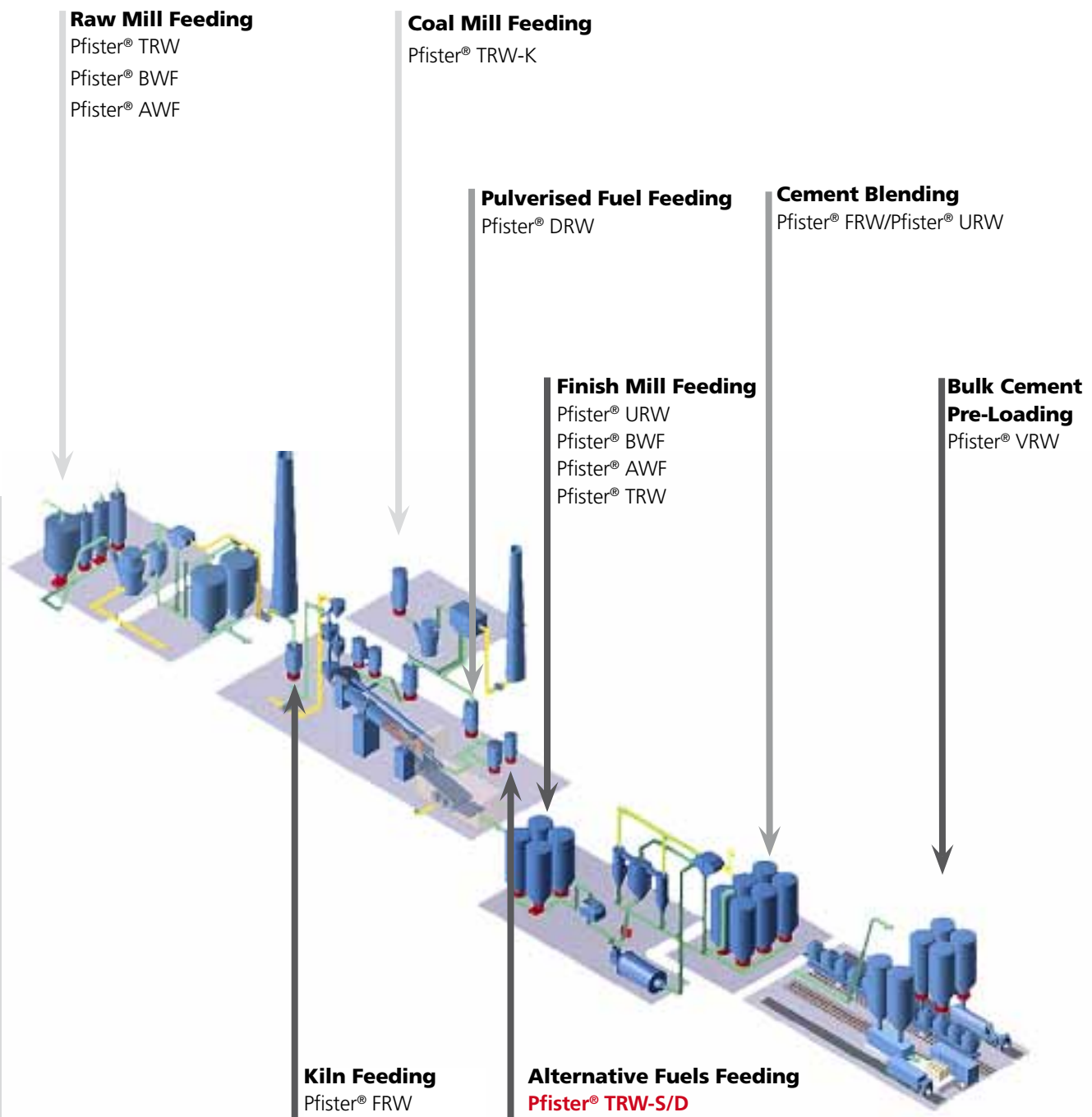

Tradition & progress

FLSmidth Pfister has almost 120 years of experience in manufacturing of industrial weighing equipment. It has been a member of the stock quoted FLSmidth Group/Denmark since 1998.

The patented rotor weighfeeder was invented by Pfister in 1984 to feed pulverised fuels for the cement burning process. This state-of-the-art dosing device has proved its properties in more than 2,800 installations worldwide.

FLSmidth Pfister additionally supplies know-how for equipment, related to the coal feeding process in order to ensure problem-free material handling and optimal pneumatic transport of the fuels. FLSmidth Pfister also designs individual installation solutions.

Pfister® weighfeeders are

- **engineered**
- **designed**
- **assembled**
- **tested**

**with the experience
of almost 120 years.**

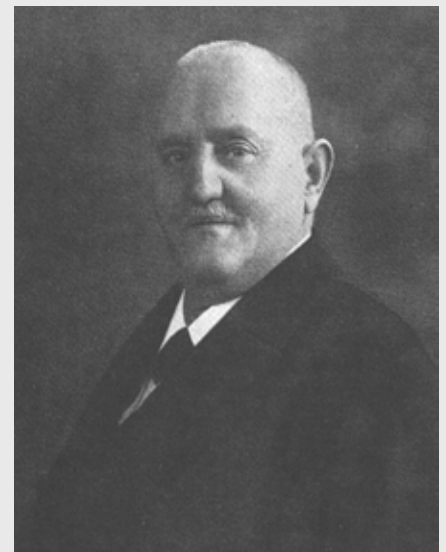
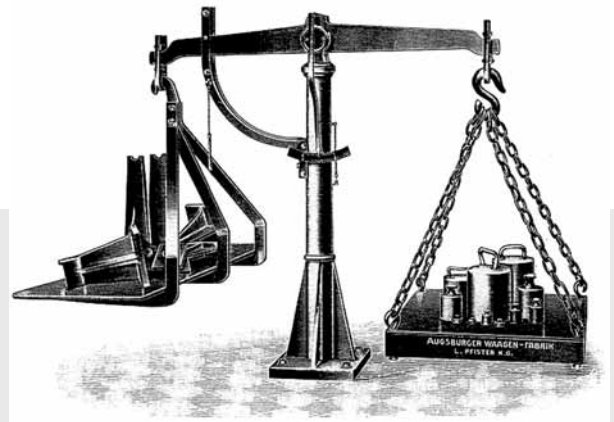

*German Ludwig Pfister founded
the company in 1894
Above: Historic scale*

Functioning principle of Pfister® rotor weighfeeders

The picture below displays rotor weighfeeder Pfister® TRW-S/D which was cut opened for illustration purposes and to demonstrate the Pfister® weighing and dosing principle:

Material is extracted out of the pre-hopper and is transported in the rotor chambers from the inlet (1) to the outlet (2). The rotor body is mounted on bearings which form a weighing axis (A-A). This axis is eccentric to the rotor shaft, and through the middle of inlet (1) and outlet (2). The third point is suspended at a load cell (3) which weighs the content in the rotor wheel gravimetrically. This means the rotor weighfeeder measures actual kilograms and is therefore a real scale. The measured gravimetric force provides information on the bulk material mass in the rotor weighfeeder before material discharge. The material load of the rotor and the related rotor wheel position, is stored by the weighing electronics. The rotor speed is controlled invers to the measured force. The rotor weighfeeder discharges the material at the outlet (2) with a highly accurate mass stream.

To achieve high accurate feeding, the speed of rotor is controlled invers to its loading.

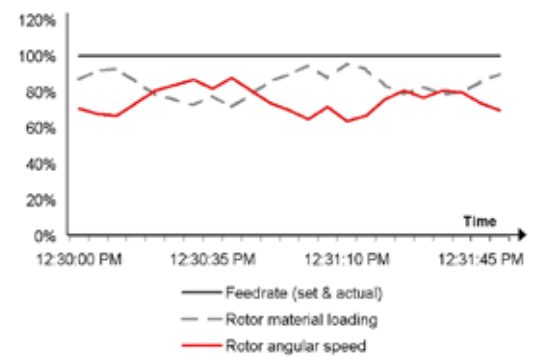

Prospective control ProsCon®: Advanced weighing electronics

The electronic controller calculates the required speed of the motor for the time of the discharge. It uses the set feed rate and the measured bulk material mass to calculate the angular speed of the rotor (see chart). Less material in the rotor results in a higher angular speed, more material in a lower speed.

With this pro-active principle, the prospective control ProsCon®, Pfister® rotor weighfeeders achieve highly accurate compensation of variations in rotor loading and material density. This results in an extremely accurate short- and long-term feed rate.

- 1: inlet
- 2: outlet
- 3: load cell
- 4: motor
- 5: rotor body
- 7: rotor with large chambers
- A-A: eccentric weighing axis

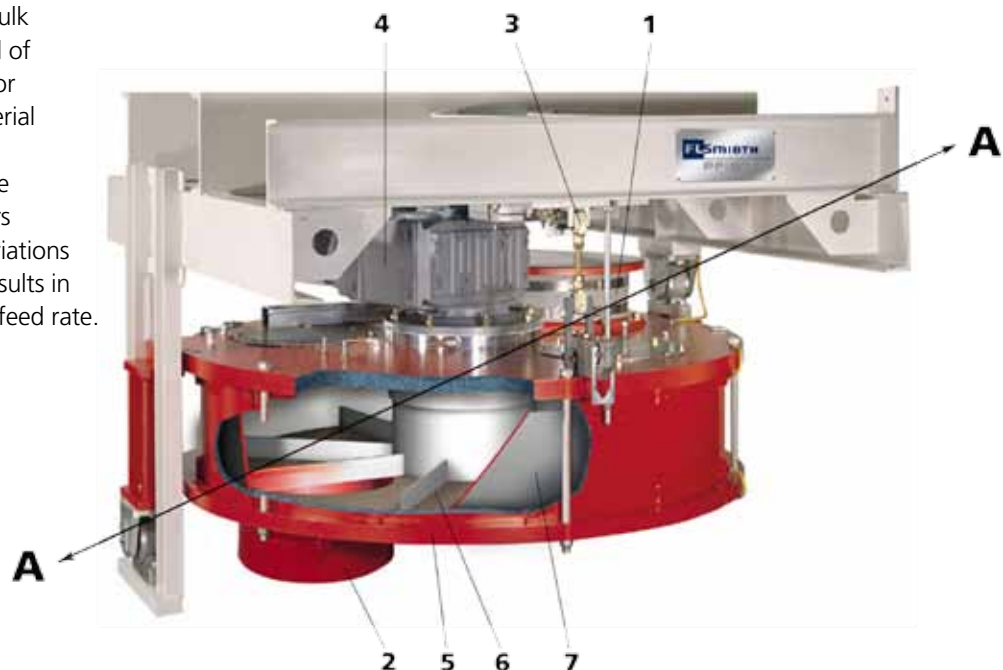

Customer benefits of Pfister® rotor weighfeeders

Outstanding reliability & long service life

- Simple design with minimal number of functional parts
- Slowly moving rotor
- Material transported in rotor chambers

High short- and long-term accuracy

- Prospective control ProsCon® (see below)
- Online calibration during operation if pre-hopper is equipped with load cells
- Insensitive to pressure fluctuations in the process

Intuitive operator interface

- The rotor weighfeeder is an advanced mechatronic system
- However, it is easy to operate
- Flexible, reliable communication to the local plant control system

Easy maintenance

- All measuring parts and drives are accessible from the outside
- No cleaning necessary
- Integration of material extraction, weighing, feeding and dosing in one system

Instantaneously adjustable feed rate

- High accuracy in a range from 10% - 100% of maximum feed rate
- Feed rate can be adjusted promptly without loss in accuracy
- Prospective control ProsCon® ensures virtually no reaction time in changes of the feed rate

Reactive Control compared to Proactive Control Strategy

Other feeders are based on a reactive control (follow-up) rather than a pro-active control. With a reactive control deviations in material loading are measured and thus pre-feeding is adjusted. The measured deviation is sent to the process. A sensitive pre-feeding device is required here.

With the pro-active rotor weighfeeder, the material mass is measured before it leaves the rotor weighfeeder. That means that the speed of the rotor is adjusted before the material gets discharged into the system. The result is an extremely high accuracy.

Customer Benefits of rotor weighfeeder Pfister® TRW-S/D

Completely dust-tight

Feeding systems handling the above described materials should be absolutely dust and air-tight. This prevents environmental pollution and the emission of dust or odor. However the necessary maintenance work should be minimal and easy to fulfil. Rotor weighfeeder Pfister® TRW-S/D realises both. The rotor weighfeeder is a completely closed unit and dust-free.

Minimal maintenance

Maintenance work at the rotor weighfeeder is kept on a minimal level since all machine parts in contact with material are fully steel. There is only one rotating part, the rotor wheel itself. There is no segregation of dust or spilled dirt at belt rollers or idler bearings. To rule out dust penetration the centre bearing is additionally purge air-sealed. Thus, even with very dusty materials, there is less cleaning of the inside necessary.

Fuel homogenisation in the silo

The pre-feeder with stirrer arm above the rotor weighfeeder provides several advantages. It homogenises the material by a stirrer to give an steady fuel quality. Additionally it ensures a steady loading of the rotor weighfeeder even if there is a short interruption of material supply or if the pre-feeder is fed over a longer distance. Together with load cells it can be used for periodically online calibration of the rotor weighfeeder. That means that the static weighing result of the material content difference in the homogenisation silo can be compared with the continuous weighing result of the rotor weighfeeder.

*All rotor weighfeeders
Pfister® TRW-S/D are
tested in the German workshop*



Multi-fuel system

Rotor weighfeeder Pfister® TRW-S is a multi-fuel system. One of the major issues when dealing with solid alternative fuels is to find a reliable supplier. It is most likely that the source and therefore the material characteristics change.

FLSmidth Pfister has experience in nearly all kinds of materials. Because of the large amount of weighed material in the system, it is possible to feed fuels with a very low density. The system is designed to handle fuel material densities from 0.05 t/m³ to 1.5 t/m³ with the same machine, so that there is maximum flexibility for the customer.

High feeding accuracy

Rotor weighfeeder Pfister® TRW-S is dosing with high accuracy resulting in a guaranteed maximum deviation of the actual and set feed rate of ± 1.0 %. Along with the high reliability it supplies fuel feeding for a very constant kiln operation.

Very light materials such as plastic could be difficult to measure because of their very low gravimetric force. This is solved with Pfister® rotor weighfeeders measuring a material layer of up to 500 mm in the feeder without the risk of material spilling. The relatively large mass of bulk material in the Pfister® rotor weighfeeder leads to a high momentary load in the measuring section of the feeder.

Explosion- proof

When feeding burnable material there is always the danger of unintentional fires or even explosion of dusty materials. In some countries it is necessary to have an explosion proof equipment when handling such dangerous materials.

The Pfister® secondary fuels dosing system can be designed explosion-proof for up to 10 bars pressure overload. Rotor weighfeeder Pfister® TRW-D is approved according to EC-type examination.

**Highly accurate
feeding of fuel is
the basis of stable
kiln operation!**

Structure of the dosing system: F-Control™ + dosing machine

F-Control™ dosing control system is used for continuously operating gravimetric feeders like rotor weighfeeders, belt weighfeeders, etc.

The main structural elements are a control cabinet FCC located in the plants motor control center (MCC) and local control panels (LCP) specifically designed for the environment surrounding the rotor weighfeeder (FIELD).

The control cabinet FCC contains all controller parts for dosing and regulation of the rotor speed. This also includes the monitoring of these functions.

The local control panel(s) LCP contain the interface to link the F-Control™ dosing control to the process and all devices to provide local access for maintenance and service operation.

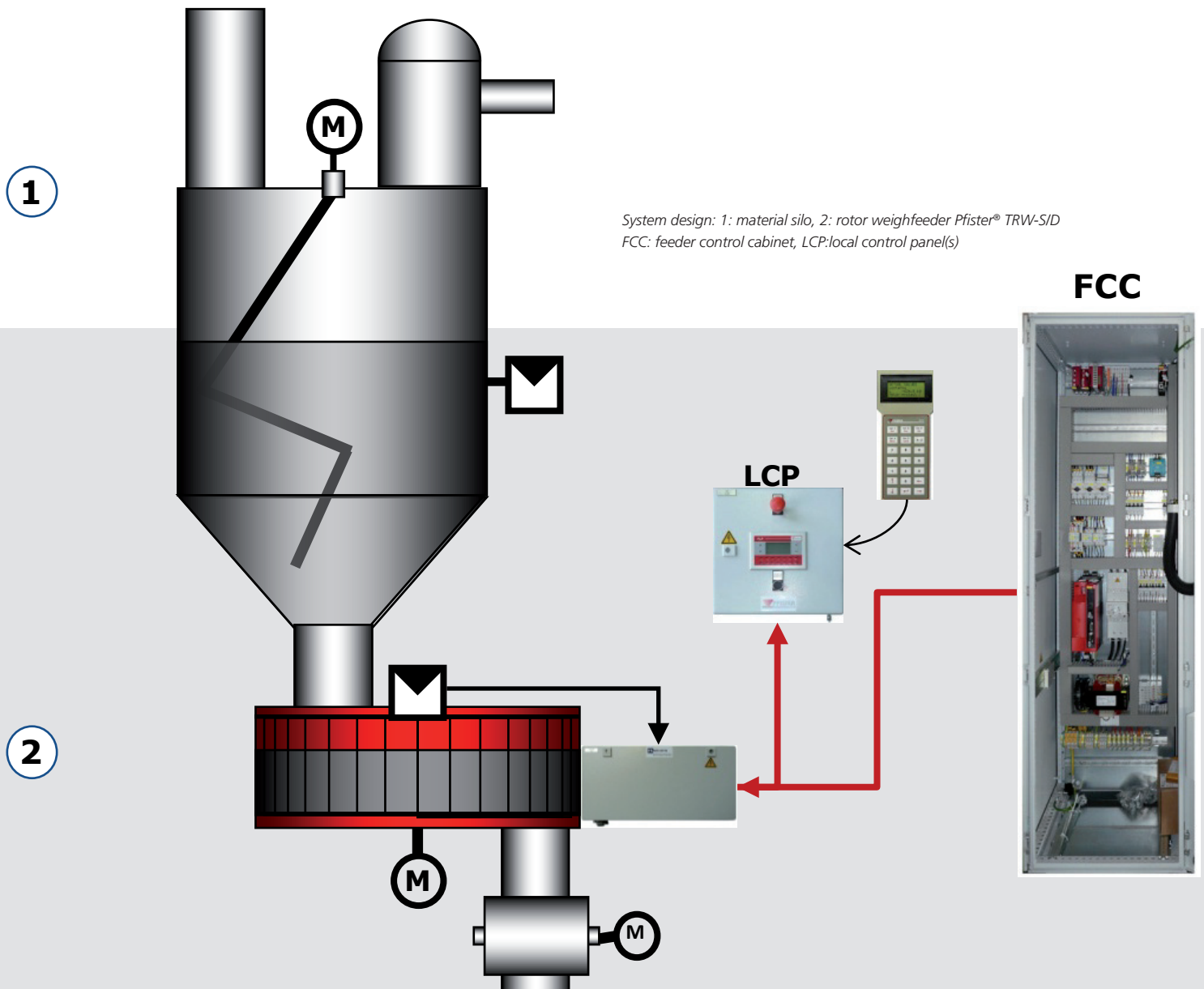

Multifuel dosing with rotor weighfeeder Pfister® TRW-S/D

A complete metering system with matching functional units has been developed over a period of years. It is optimised for a large number of various alternative fuels in FLSmidth Pfister's own research centre, and tested over long periods of continuous practical operation.

Rotor weighfeeder Pfister® TRW-S/D meets the following requirements:

- Stable fuel dosing
- Outstanding reliability
- High short- and long-term accuracy
- Compact, robust, closed dosing system
- Optional explosion-proof design
- Large feeding range
- Online calibration during operation
- Easy to maintain

The complete metering system can also be designed as a pressure-shock resistant and ATEX executed model (rotor weighfeeder Pfister® TRW-D) to meet the requirements for alternative fuels and biomass.

This means that a wide range of alternative fuels can be metered while complying with the relevant safety regulations.

Please note: Rotor weighfeeder Pfister® TRW-S/D can be used for mechanical or pneumatical transport.

- (1) infeed
- (2) stirring device
- (3) level limit switch
- (4) homogenisation silo with stirrer arm
- (6) rotor weighfeeder Pfister® TRW-S/D
- (7) ventilation box with ventilation pipe
- (8) rotary valve with ejector shoe
- (9) blower fitting
- (10) load cells for online calibration

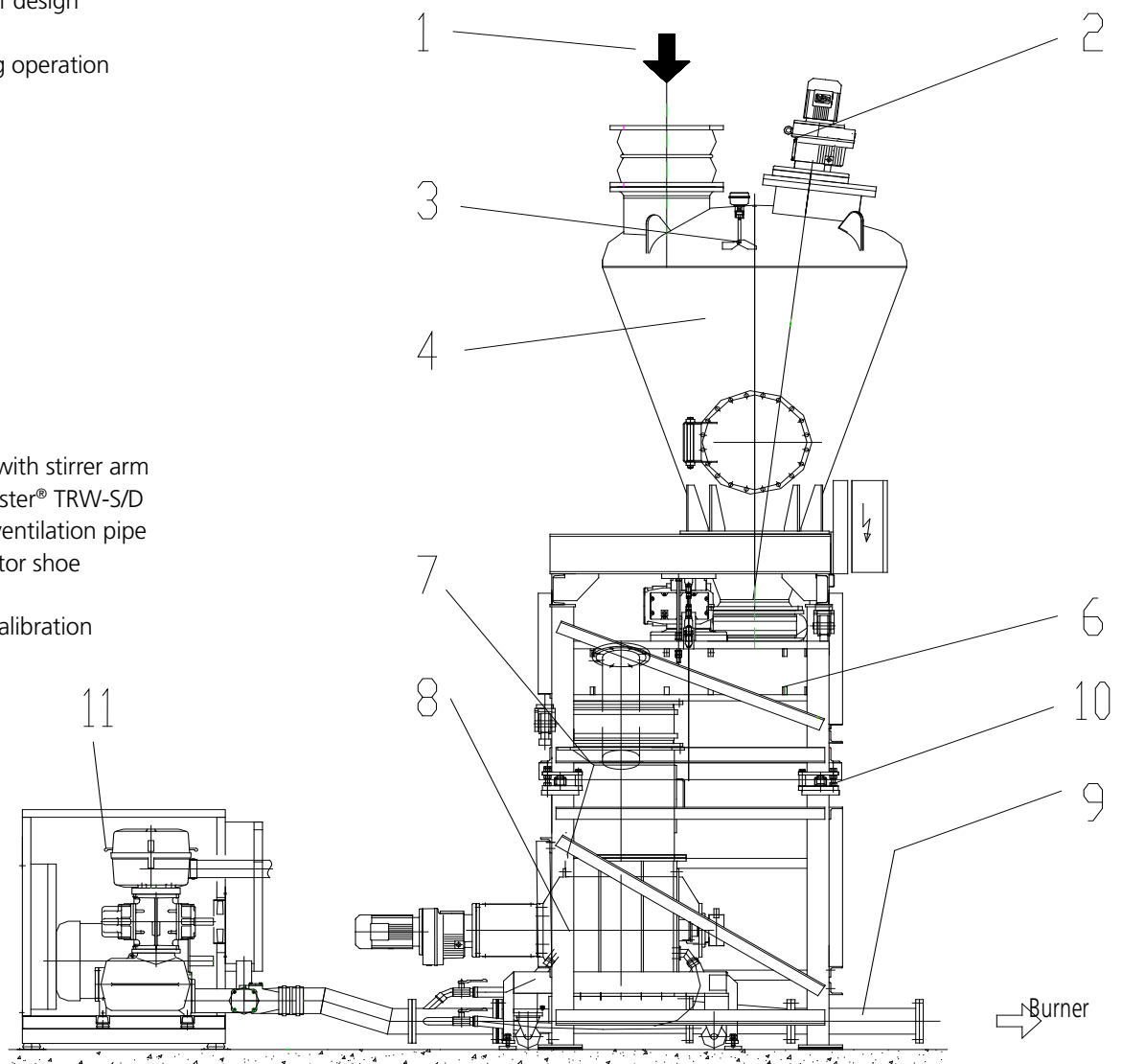

Multifuel dosing with rotor weighfeeder Pfister® TRW-S/D

**Alternative fuels
are also known as**

- refuse derived fuels (RDF)
- clima fuels
- secondary fuels
- biomass (e.g. wood chips, saw dust, sewage sludge, animal meal)
- industrial waste

The pictures on the right display a selection of alternative fuels which are handled by a rotor weighfeeder Pfister® TRW-S/D.

This multifuel device is able to handle different alternative fuels no matter whether these are dry or moist, chipped or chunky.

Even if the composition and consistency of the fed alternative fuels are varying, rotor weighfeeder Pfister® TRW-S/D can handle them - all with one and the same system.



animal meal



carpet waste



textiles



car-plastic



paper



bottle caps



rice straw and husk

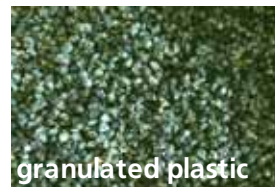

granulated plastic



rubber chips



grinding dust



sewage sludge



saw dust



sunflower shells



nappies



tetra pack



household waste

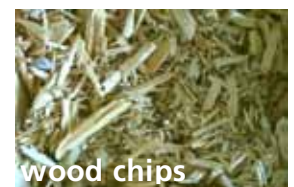

wood chips

Technical facts of rotor weighfeeder Pfister® TRW-S/D

- Application fields:** Kiln and calciner firing process
- Fuels:** Extremely light or very heavy materials such as FLUFF, RDF, sewage sludge, plastics, animal meal, paper and wood waste, impregnated saw dust, oil soaked textiles, carpet pellets, tyre chips, various shells or biomass. Handling of different materials with one and the same rotor weighfeeder Pfister® TRW-S/D is possible.
- Dosing capacity:** Up to 25 t/h with densities down to 0.05 t/m³
- Design example:**
- Rotating discharge screw
 - Shut-off gate
 - Flexible joints
 - Calibration pre-hopper with stirrer
 - Rotor weighfeeder Pfister® TRW-S/D
 - Rotary valve for transfer into the pneumatic feeding line
- Features:**
- Stable fuel dosing
 - Outstanding reliability
 - High short- and long-term accuracy
 - Dosing of varying fuels possible with one and the same rotor weighfeeder Pfister® TRW-S/D
 - Compact, robust, closed dosing system
 - Explosion-proof design optional
 - Large feeding range
 - Online calibration during operation
 - Easy to maintain
- Dosing control:**
- Feeder dosing controller Pfister® FDC
 - Prospective control ProsCon®
 - FlowBalance™ control
 - User oriented interfaces
 - Remote service access available
- Certificates:** ATEX in categories II1/2D and II1/3D, ISO 9001

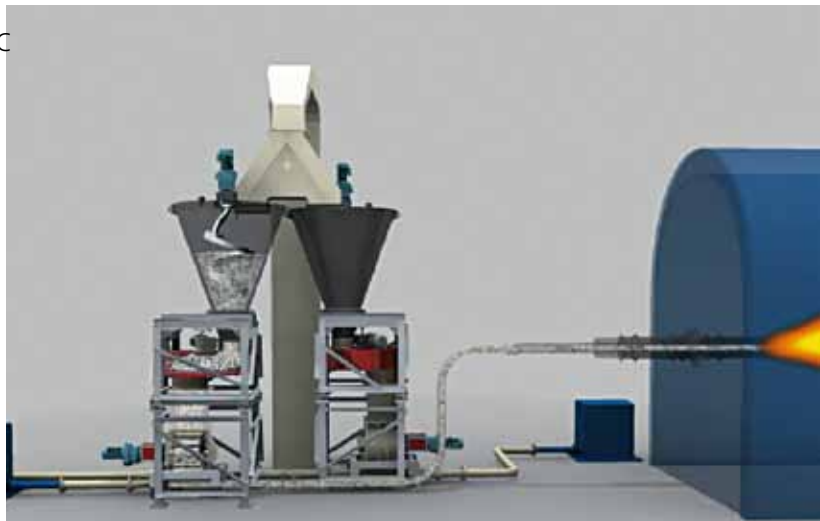
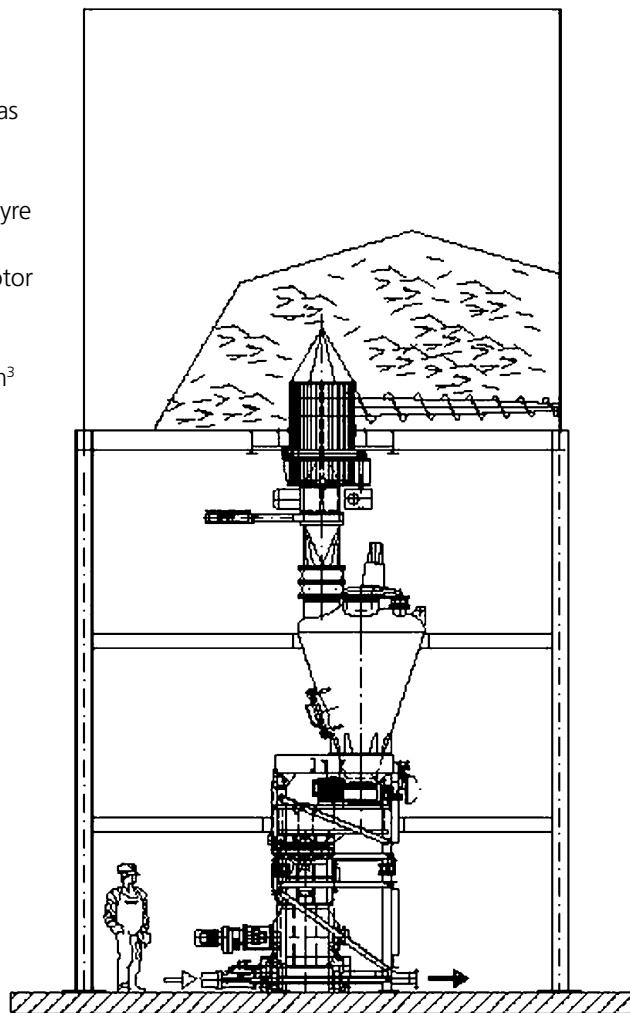

Solutions with rotor weighfeeder Pfister® TRW-S/D

Installations and applications with rotor weighfeeder Pfister® TRW-S/D are possible for every single section of alternative fuel plants and are designed to the needs of the specific application.

Pilot Plant

The easiest way to start burning alternative fuels is a pilot plant as shown below. The material gets delivered by walking floor trailers to a docking station. A screw conveyor transports the material in the docking station to the central chain conveyor which itself transports the material up to the pre-feeder where the dosing process starts as described earlier.

Different unloading systems

Installations with rotor weighfeeder Pfister® TRW-S/D can be configured for all kinds of material unloading installations for example for systems with belt or chain conveyors, life bottom systems and/or truck passable systems (see pictures on the right).

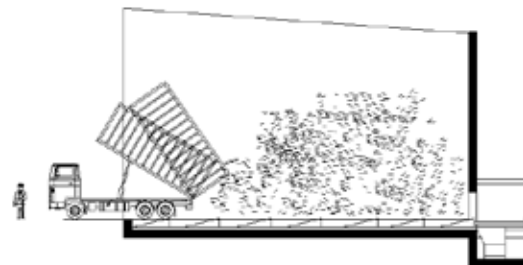
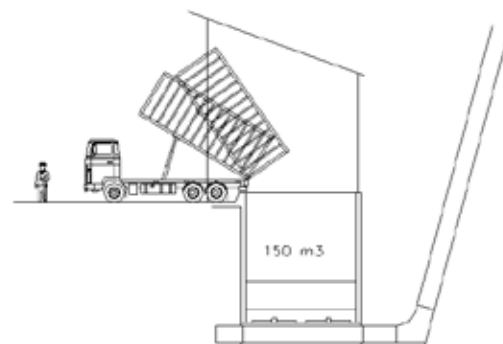
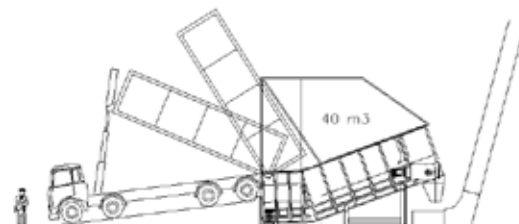

Pilot plant consisting of truck-trailer docking station, trough chain-conveyor and Pfister® TRW-S with pneumatic transport

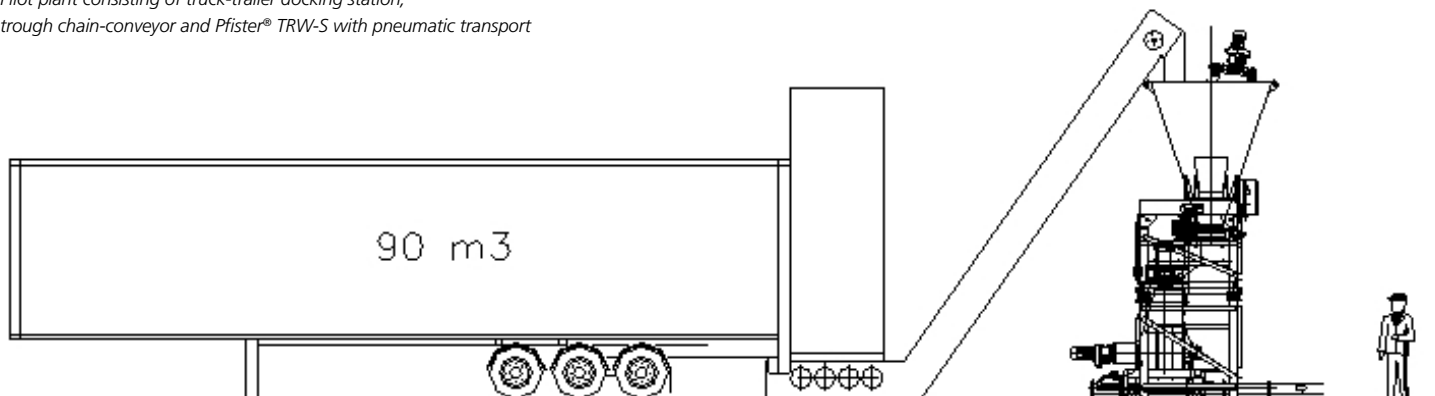

Material storage systems

Installations with rotor weighfeeder Pfister® TRW-S/D have been realised with a number of different silo and storage solutions. There are virtually no limits in material storage and retrieval design. The pictures below display examples for a storage hall with intermediate silo, automatic crane and truck receiving station, a silo with walking floor extraction and a silo with a rotating screw extractor.

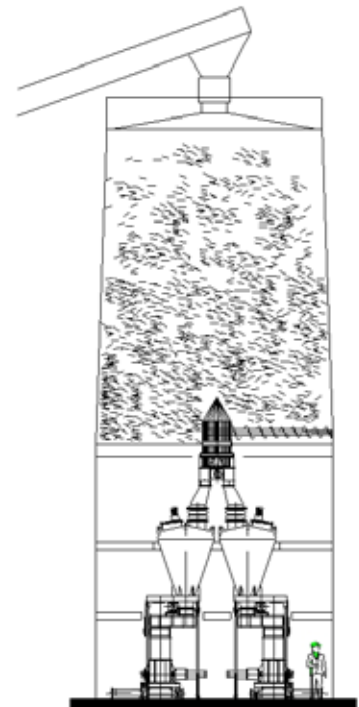
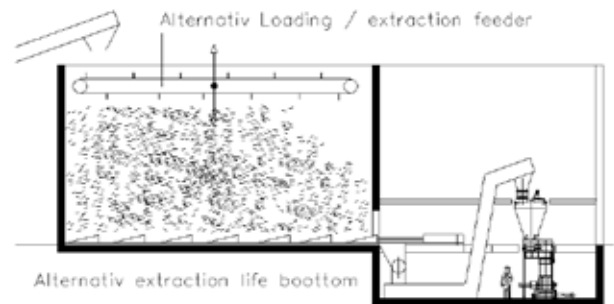
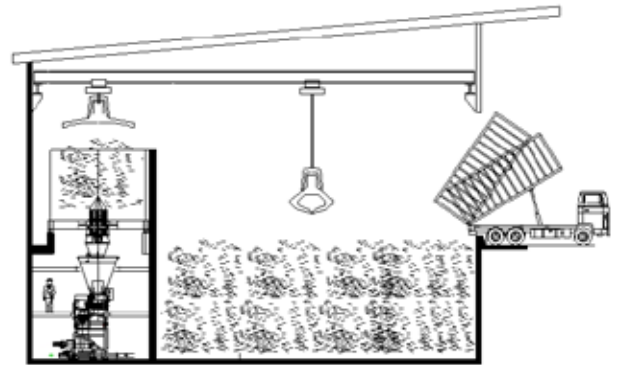

Applications with Pfister® TRW-S/D: Alternative fuels feeding to a main burner

In this installation rotor weighfeeder Pfister® TRW-D is utilized for feeding fluffy and dusty alternative fuels with a feed rate of 8 t/h. For this purpose rotor weighfeeder Pfister® TRW-D is executed in ATEX and shock pressure-proof design.

Upper picture:
Homogenisation silo, rotor weighfeeder

Lower picture:
Rotary valve with blow shoe for pneumatic transport



Märker Zement, Germany

Märker cement plant operates an advanced alternativ fuels system since 2002. It burns RDF from industrial production and waste wood chips. The industrial waste is processed in a preparation plant directly on site. The wood chips are delivered by container truck directly to one of the three storage boxes (picture below left). All materials is transported by a chain conveyor and homogenised in the FLSmidth Pfister® pre-feeder. Rotor weighfeeder Pfister® TRW-S/D doses the material which is then pneumatically transported to the main-burner after the rotary valve. Rotor weighfeeder Pfister® TRW-S/D is currently running at 6 t/h, about 50 % of its maximum feed rate.

The picture below on the right displays a chain conveyor transporting the material from the three storage boxes to the FLSmidth Pfister® pre-feeder. The rotary valve for pneumatic transport is on the floor beneath.



Südbayerisches Zementwerk, Germany

Südbayerisches Zementwerk in the town of Rohrdorf in the vicinity of Munich has a long history of burning solid alternative fuels since it started in 1997. The plant burns RDF from industrial production in the Munich area as well as Tetra Pack shavings. The preparation plant is off-site and the material gets delivered to the plant by truck via two receiving stations. On-site the material is stored in big storage halls equipped with cranes which handle the material and fill the intermediate silos. Three rotor weighfeeders Pfister® TRW-S/D are used since different materials get mixed into the burning process with a total feed rate of 10 t/h. Rohrdorfer Zement also fires tire chips and liquid secondary fuels. The substitution rate of secondary fuels is in total up to 90% and the half of it by solid secondary fuels.

Pictures from above display:

- the truck receiving stations
- the storage hall with an automatic crane for material handling
- two FLSmidth Pfister® pre-feeder silos and rotor weighfeeders. In this picture two different materials get mixed into the rotary valve for pneumatic transport to the burners.



Gmundner Zement, Austria

Gmundner Zement is located close to Salzburg in Austria. The plant is very compact and clean because of strict emission regulations since located in a touristic area. The plant shows a very good example to receive, store, handle and dose solid secondary fuels. The waste is prepared off-site. The pictures on this page display the plant as well as its scheme. The plant is executed according to ATEX regulations.

Alternative fuel gets delivered by truck (1) to the storage hall (2). The automatic crane (3) transports and mixes the material into the intermediate silo (4). From there the material gets extracted by a rotating screw towards a screen and metal detector (5). An pre-feeder with stirrer arm feeds the material to rotor weighfeeder Pfister® TRW-D (6). The rotary valve hands over the material to a pneumatic transport (7). A filter (8) is used for dedusting the process.

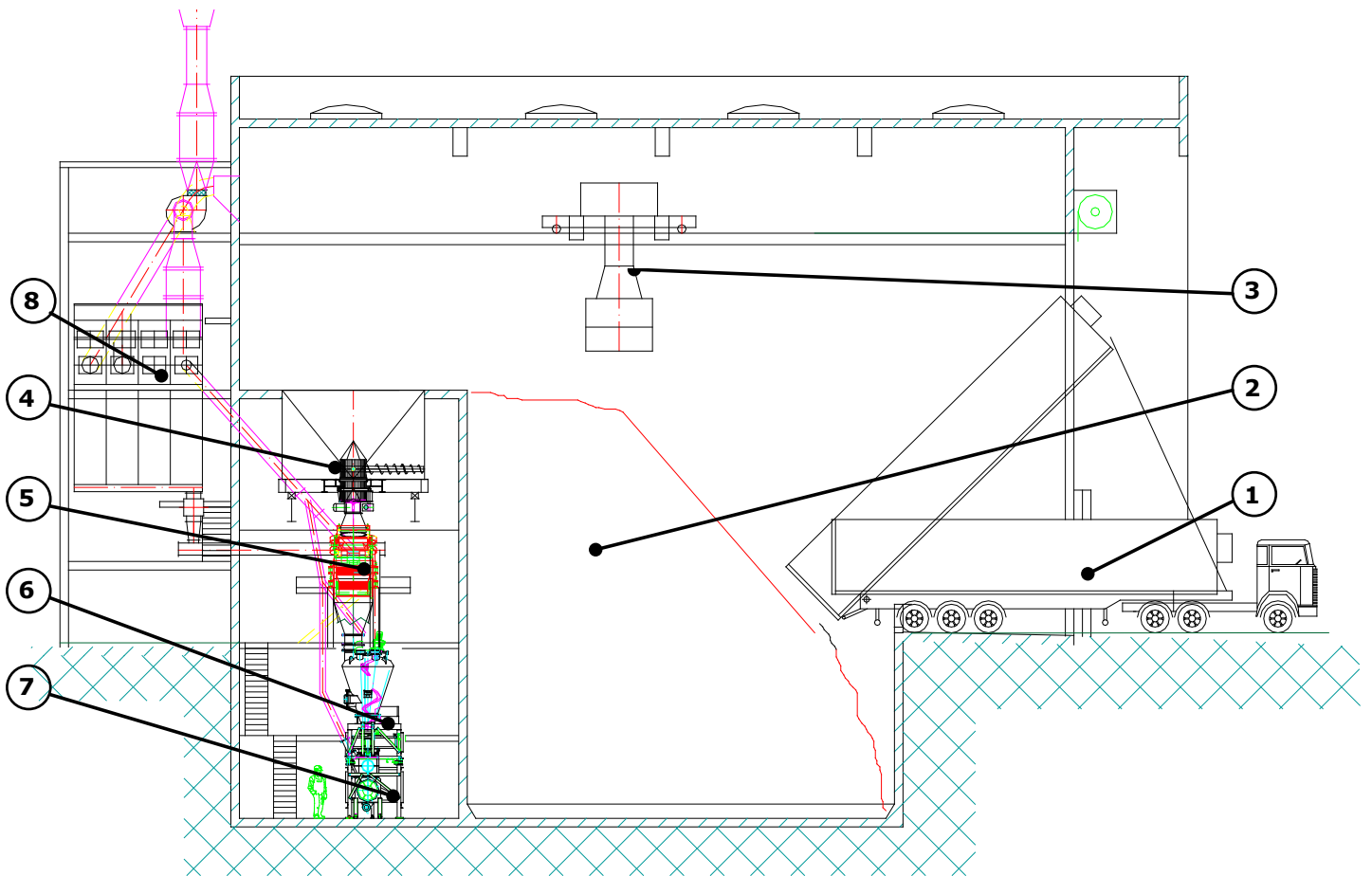

Gmundner Zement, Austria

The picture on the right shows the automatic crane which is used to transport the material from the storage hall to the intermediate silo. The picture below shows the intermediate silo with bottom screw extraction.

Alternative fuels are screened in the metal detector shown below (left).

The material is fed to Pfister rotor weighfeeder Pfister® TRW-D (picture below right) and accurately dosed into a rotary valve for pneumatic transport to the burner.



German design & assembly of Pfister® rotor and belt weighfeeders

Pfister® weighfeeders are engineered, designed and assembled at FLSmidth Pfister's headquarters in Augsburg/Germany and at their workshop in India.

An experienced team of engineers and technicians tests all equipment at their own test systems. In addition, Pfister® spares and parts are kept in stock for immediate disposal.

*FLSmidth Pfister assembles all weighfeeders
in Augsburg/Germany and in India*



Engineering & design

FLSmidth Pfister® engineering services comprise:

- **Planning of the installations**
- **Silo engineering**
- **Calculation of pneumatic transport**
- **Further engineering services**

FLSmidth Pfister does not only supply the single dosing machines. FLSmidth Pfister's know-how includes the complete setup and surrounding of the installation like silo engineering, intermediate material transport and safety equipment.

That ensures that customers get all engineering from one experienced partner and one single source.

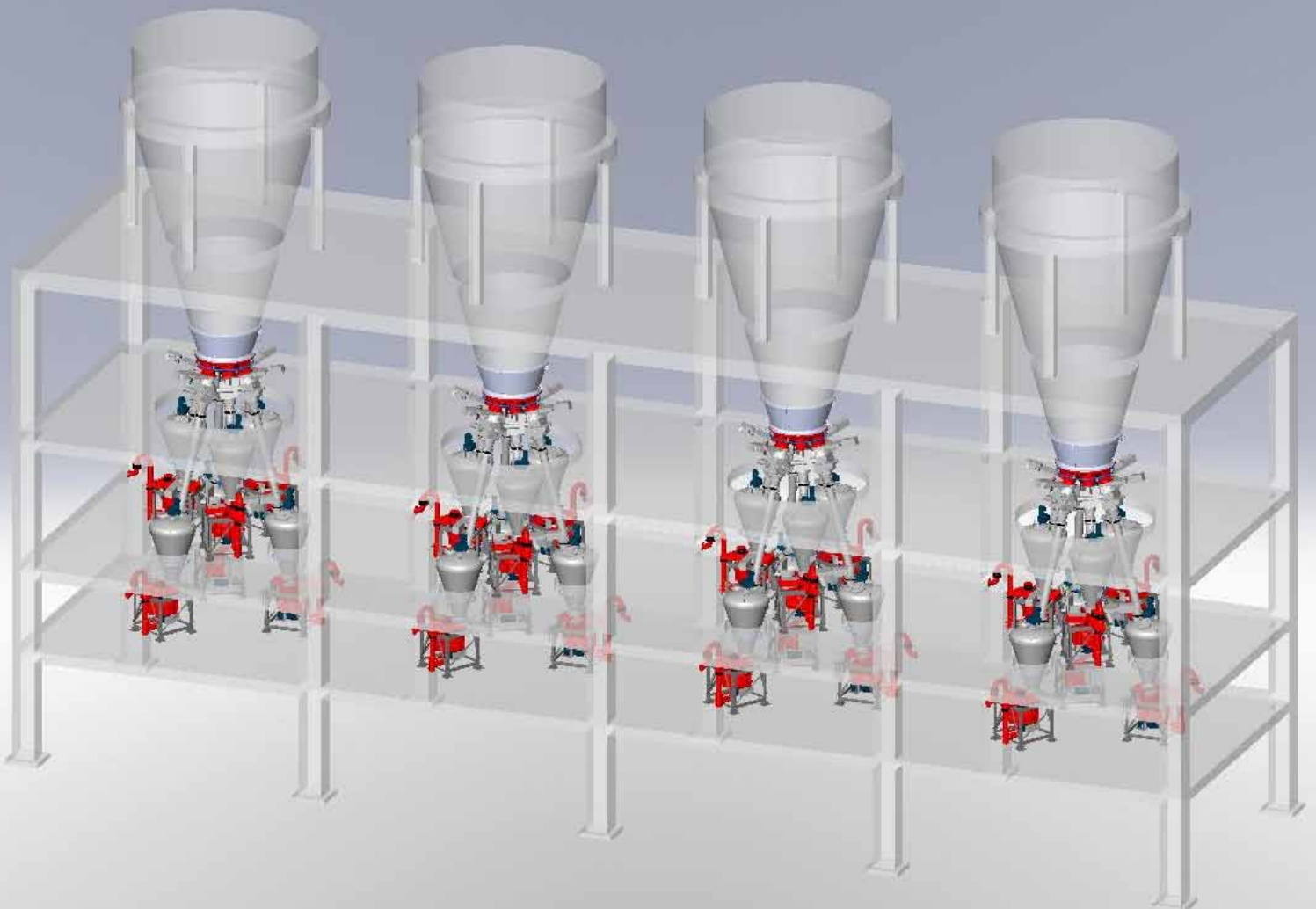

One-stop shop: FLSmidth Minerals Group

Installation example

- **FLSmidth Wiesbaden:**
Building, Koch™ bin with extraction unit, Koch™ screw conveyors
- **FLSmidth Pfister:**
**4 x rotor weighfeeders
Pfister® TRW-D 4.14 with pre-hoppers; capacity 6 t/h, multifuel application**
- **FLSmidth Hamburg:**
Möller™ conveying transport

FLSmidth is the leading supplier of equipment and services to the global cement and minerals industries. For the power generation industry FLSmidth combines its know-how and expertise as a supplier for complete systems and components from the entire group - all in keeping our slogan: One Source.

FLSmidth brand names for the industry:

- **Dorr-Oliver®, Eimco®, Krebs®** - world market leaders in machinery and equipment for liquid/solid separation, principal suppliers for gypsum dewatering systems in power stations
- **Koch™, MVT™** - material handling technology
- **Möller™** - pneumatic conveying systems and silo technology
- **Pfister®** - experts for continuous gravimetric weighing and dosing



Pfister® customer service & after sales support

Thousands of FLSmidth Pfister® systems are currently in operation worldwide and require global presence. Therefore FLSmidth Pfister operates sales and service offices in eight countries on four different continents.

Experienced service technicians stand by your side and provide first-class service. A 24-hour hotline and online troubleshooting provide worldwide support. Also available are telesupport packages.

FLSmidth Pfister not only keeps a large number of spare parts in stock. Skilled spares specialists are looking forward to assist you in optimizing your own spare parts management.

FLSmidth Pfister® services are rounded up by service contracts, which can be adapted individually to the customer's needs.

Customer training on-site or at FLSmidth Pfister® training center ensures the best possible knowledge transfer.



Pfister® after sales support:

- **24-hour Hotline**
- **Telesupport**
- **Modern Maintenance Management**
- **Trainings and Seminars**
- **Service Contracts**

FLSmidth Pfister's headquarters are located in Augsburg / Germany



Headquarters:

FLSmidth Pfister GmbH
Staetzlinger Str. 70
86165 Augsburg, Germany
T. +49 821 7949 0 | F. +49 821 7949 524

Sales Department: sales@flsmidthpfister.com
Technology Department: engineering@flsmidthpfister.com
Service Department: service@flsmidthpfister.com

Branch offices & joint ventures:

FLSmidth Pfister Inc.
2158 Avenue C, Suite 201
Bethlehem, PA 18017-2148, U.S.A.
p. +1 610 2645110 | f. +1 610 2645537
pfister.usa@flsmidthpfister.com

FLSmidth Pfister Ltda.
Rua Vigario J.J. Rodrigues, 905 - cj. 51
13.201 - 490 Jundiai, S.P. Brazil
p. +55 15 34167430 | f. +55 11 45875711
thiago.cosceli@flsmidthpfister.com

FLSmidth Pfister GmbH Malaysian Branch
C-3A15, Centre Wing, Metropolitan Office Suite
Metropolitan Square, Jalan PJU 8/1
Damansara Perdana, 47820 Petaling Jaya
Selangor, Malaysia
p. +60 3 7728 2039 | f. +60 3 7727 2039
pfismal@streamyx.com

FLSmidth Pfister GmbH
6, Rue de Bretagne
38070 St. Quentin Fallavier, France
p. +33 474 955544 | f. +33 474 945075
pnl@flsmidthpfister.com

Transweigh India Ltd.
124, ABCD, Govt. Industrial Estate, Kandivli (W)
Mumbai - 400 067, India
p. +91 22 6772 6000 | f. +91 22 6772 6100
sales@transweigh-india.com

FLSmidth Pfister China
Western Part of Songshan Road
Qingdao Airport Industrial Zone, Cheryang District
266109 Qingdao, P.R. China
p. +86 532 8776 03 80 | f. +86 532 8775 68 52
pfister-china@pfister.de