

Hydraulic thrust device for balanced kiln operation

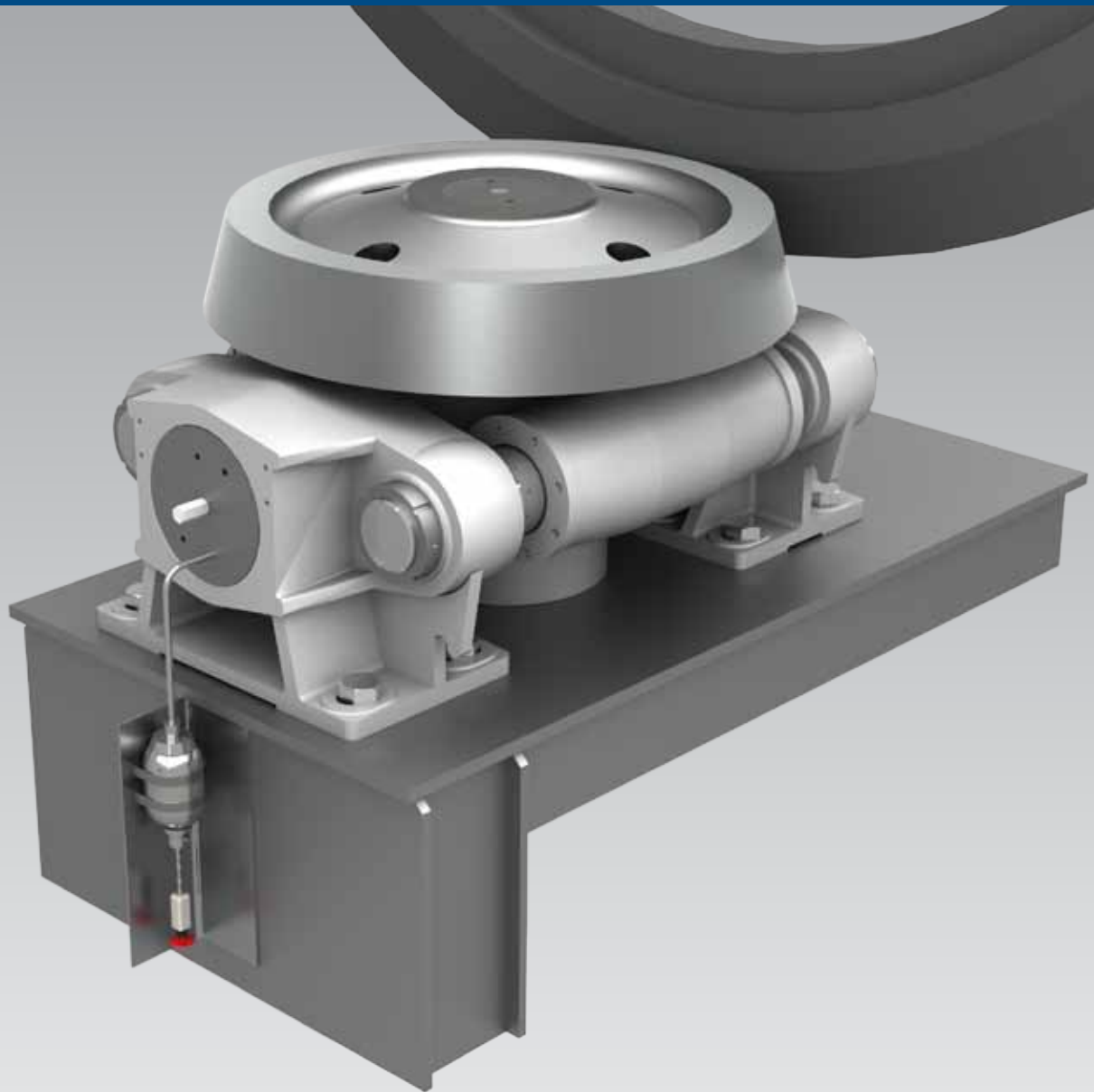

The FLSmidth hydraulic thrust device, HTD, is a proven way to optimise kiln operational stability. The functional hydraulic design ensures smooth and reliable operation.

15 days or less for implementation of retrofit HTD

Key benefits

- Improves lifetime for rolling components
- Minimises the risk of breakdowns
- Reduces maintenance costs
- Functional and proven design

Designed to perform

The automatic hydraulic thrust device (HTD) controls the kiln's axial motion. It counteracts the slope of the kiln and ensures uniform use of the contact surfaces between tyres and supporting rollers, as well as the girth gear and pinion.

The hydraulic thrust device is designed to take up the full axial load of the kiln, so skewing of the support rollers is not needed. The result is smooth operation with improved lifetime for rolling components.

Easy maintenance

For easy maintenance the pump and accumulator can be disconnected from the hydraulic circuit during production. Stable operation also reduces the exchange intervals of all rolling parts, which minimises maintenance costs.

Built-in LVDT

The built-in Linear Variable Displacement Transducer (LVDT) is placed in the hydraulic cylinder, from where it sends exact signals to the control panel and provides an alarm if the kiln moves from the pre-set position. It stops the kiln motor if the kiln position shifts beyond safe boundaries.

Integrated accumulator

The integrated accumulator absorbs and neutralizes pressure variations in the hydraulic system during floating, overload and tyre wobbling. This ensures stable and smooth operation of the hydraulic system, and minimises the risk of thrust roller damages.

Guide roller upgrade

As a result of our ongoing research and development work, the HTD includes a new and improved guide roller design. Compared to previous designs, the new

guide roller has drilled holes with optimised surface finish and fillet edges. It reduces the interference between the thrust roller and the shaft, which minimises the risk of critical breakdown situations and improves the lifetime of the guide roller.

HTD retrofit within 15 days

Retrofitting of an existing older model of thrust device or a non-FLSmidth model to the latest HTD, can be completed within 15 days. This enables you to install the updated technology during scheduled shutdown and optimise kiln availability without loss of production.

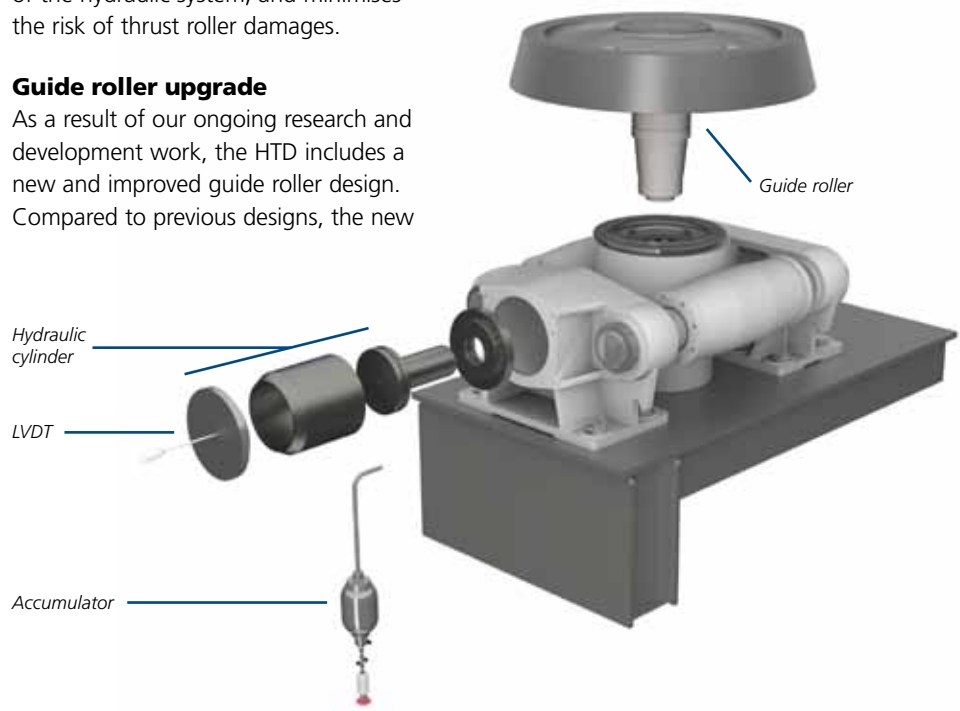

FLSmidth Denmark

FLSmidth A/S
Vigerslev Allé 77
DK-2500 Valby
Copenhagen
Tel: +45 3618 1000
Fax: +45 3630 1820
E-mail: info@flsmidth.com

FLSmidth USA

FLSmidth Inc.
2040 Avenue C
Bethlehem, PA 18017-2188
Tel: +1 610-264-6011
Fax: +1 610-264-6170
E-mail: info-us@flsmidth.com

FLSmidth India

FLSmidth Private Limited
FLSmidth House
34, Egatoor, Kelambakkam
(Rajiv Gandhi Salai, Chennai)
Tamil Nadu – 603 103
Tel: +91-44-4748 1000
Fax: +91-44-2747 0301
E-mail: indiainfo@flsmidth.com

www.flsmidth.com

